

A Real-time, Output-Targeting Beam Control System for the UHDR Mobetron

Austin Sloop, Kevin Willy, Anoill Youkhaneh, David Gladstone,
Brian Pogue, Petr Bruza
Dartmouth College

NEAAPM, February 6, 2026



Disclosures:

- This work was funded by NIH U01 CA260446
- Norris Cotton Cancer Center Shared Resources with NCI cancer center support grant 5P30 CA023108-41
- Petr Bruza and Brian Pogue are affiliated with Dose Optics LLC, which provided hardware support for this study.

State of electron UHDR / FLASH-RT irradiation:

- All irradiations relied on pre-programmed treatments and post-delivery verification of delivered dose
- There was no mechanism to monitor output in real-time and adjust the accelerator to meet a prescribed target.

DeFrancisco J, A systematic review of electron FLASH dosimetry and beam control mechanisms utilized with modified non-clinical LINACs. *Journal of Applied Clinical Medical Physics*. 2025;26(4):e70051. doi:[10.1002/acm2.70051](https://doi.org/10.1002/acm2.70051)

Our UHDR Mobetron Output Variability

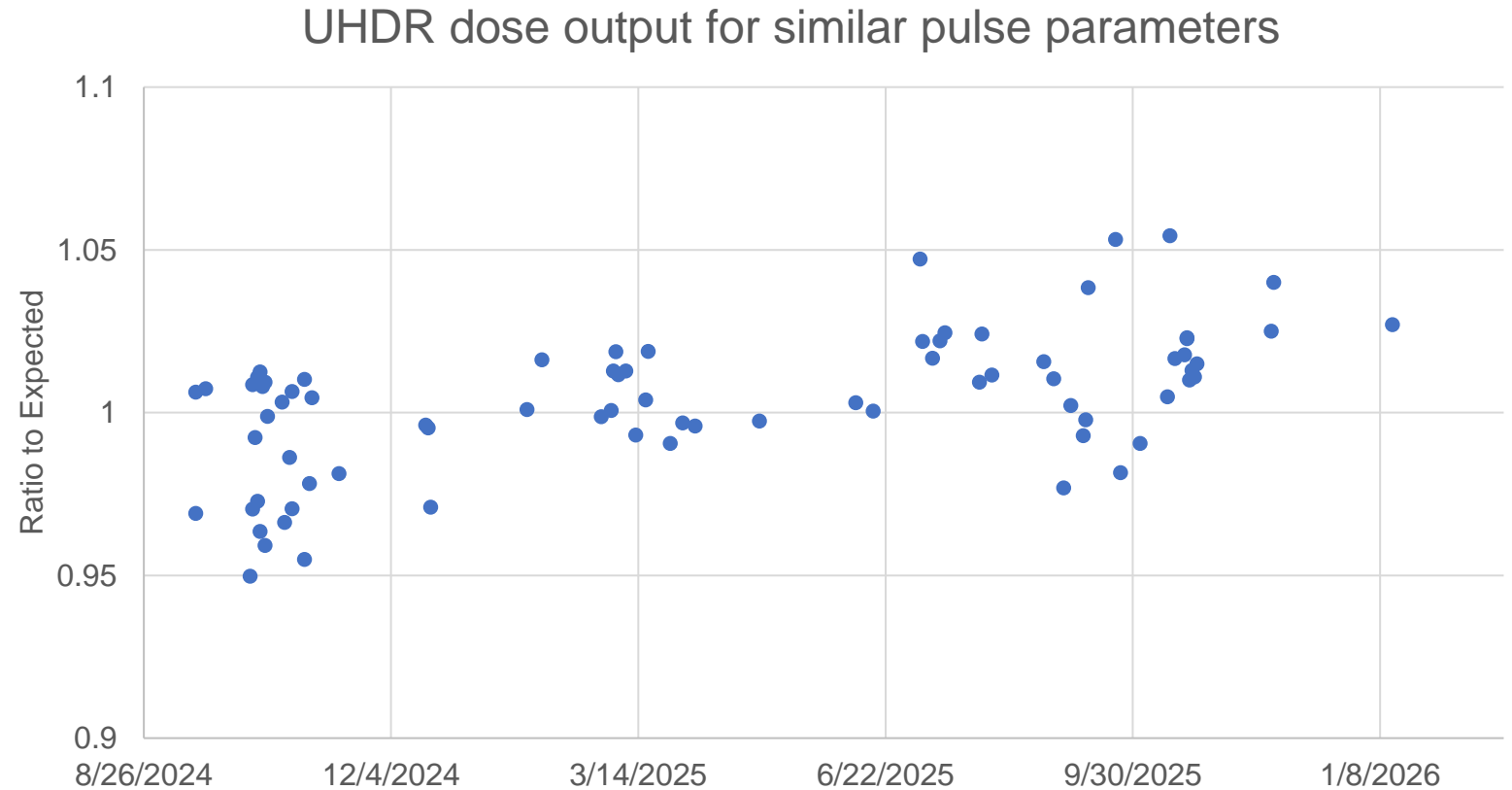
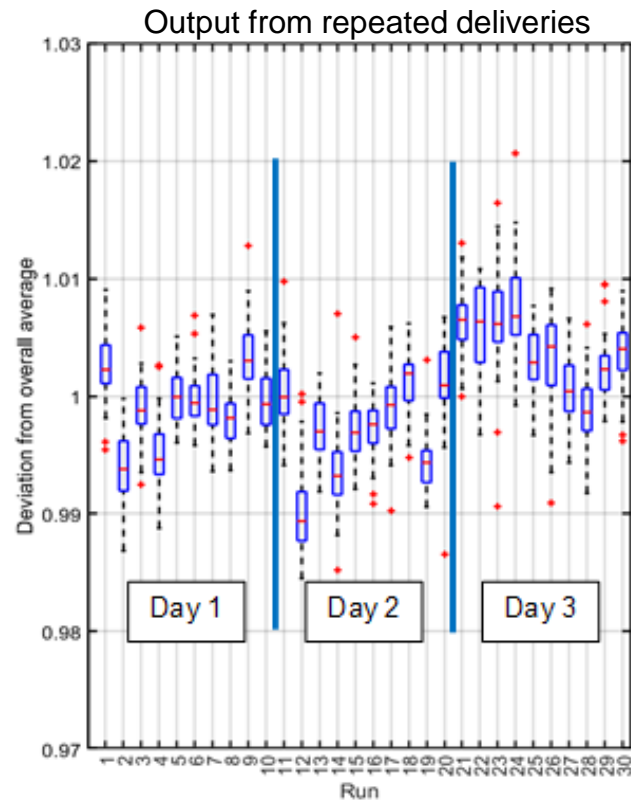

Short term / beam-to-beam
is very consistent

Long-term QA generally measured within 3% of our
targets, but we need to account for drifts

Our prior TPS could adjust for machine variability up to $\pm 5\%$ (larger excursions would trigger recalibration)

The screenshot displays a spreadsheet with two columns of data for different experimental setups. The left column is for 'UHDR' and the right for 'CONV'. Both show fields for Experiment, Date, Operators, Geometry (Applicator, Aperture, Output Factor), Planned Dose, Fluence Required, Target Depth, Mod, Recommended Beam Configuration (PW, Potentiometer, PRF, N-Pulses), Pre-Delivery QA, and IACUC Protocol.

Field	UHDR	CONV
Experiment:	ENTER EXPERIMENT	ENTER EXPERIMENT
Date:	6/12/2025	6/12/2025
Operators:	OPERATOR 1 & OPERATOR 2	OPERATOR 1 & OPERATOR 2
Geometry:		
Applicator:	Short_Cone	Long_Cone
Aperture:	4.5	GR S/L6
Base Output Factor:	2.093 [cGy/FU]	0.9559 [cGy/MU]
Output to Target:	2.09295 [cGy/MU]	0.95586 [cGy/MU]
Planned Dose:	15.00 Gy	15.00 Gy
Delivered:		
Fluence Required:	716.7	
Target Depth:	1 cm	1 cm
Mod:	1.000	1.000
Recommended Beam Configuration:		
PW:	1.363 (variable) μ s	
Potentiometer:	9.39	
PRF:	90 Hz	
N-Pulses:	4	
Pre-Delivery QA:	1.000	1.000
Enter Charge in nC:	0	0
IACUC Protocol:		

This cannot prevent under/over-dose situations if the machine malfunctions.

Core Technological Hurdles to Improve the Safety and Reliability of UHDR Deliveries



Measure dose per-pulse
in real-time

Manipulate the
accelerator to adjust
per-pulse output

Real-time Output Measurements

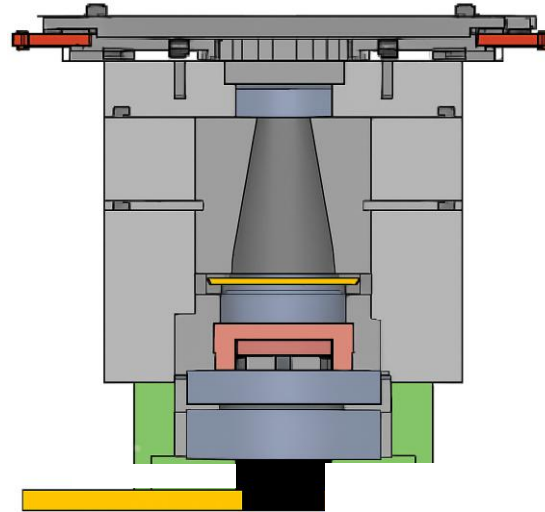

A PLA adapter places the EDGE diode in the periphery of the beam at the exit window

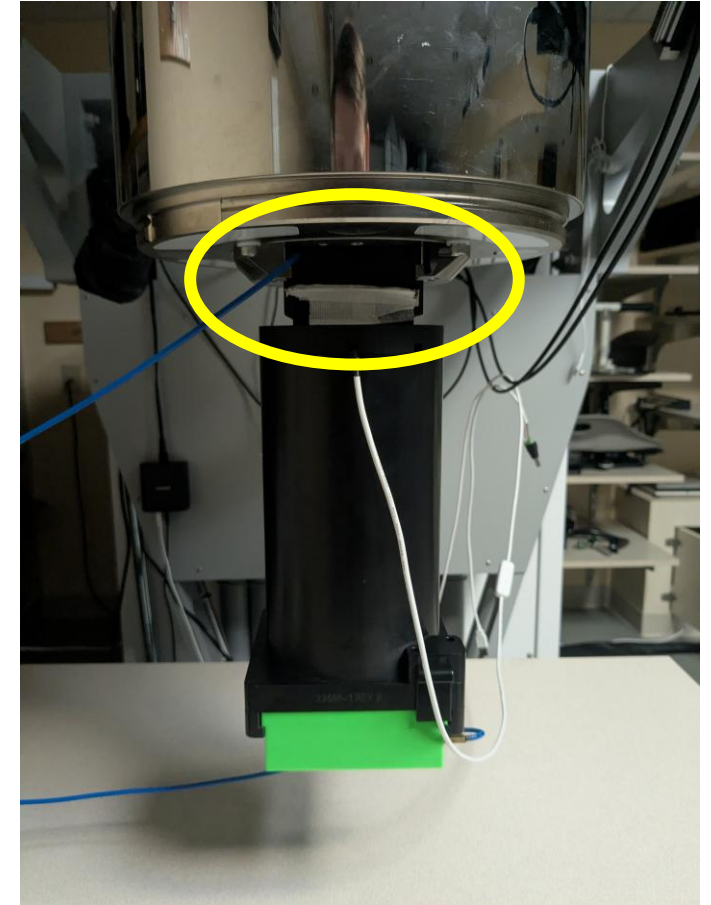

Real-time dose measurements

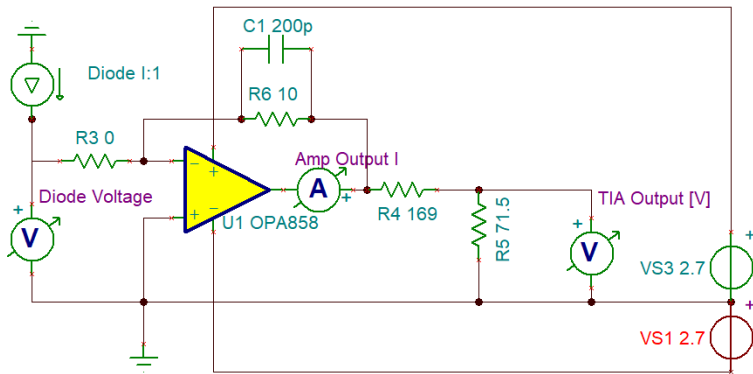

A custom transimpedance amplifier produces a voltage signal from the high current produced by the EDGE.

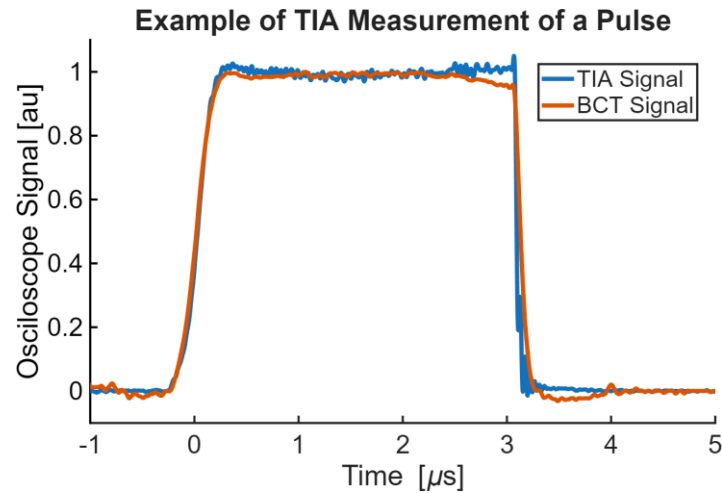

This signal is linear against radiation intensity.

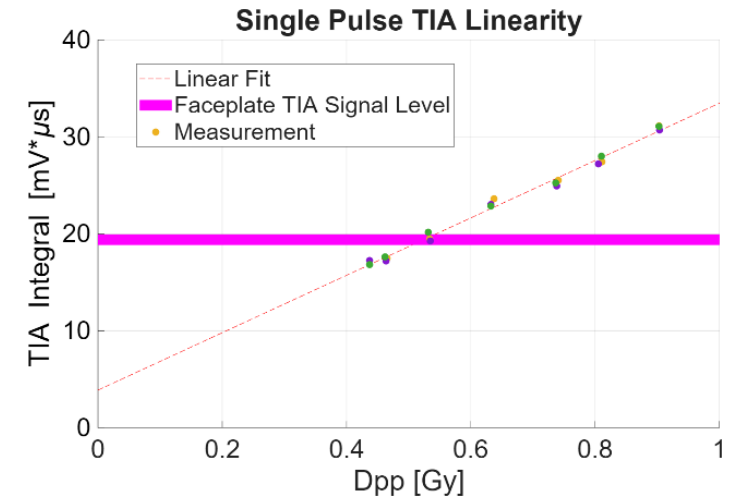

The integral signal is proportional to dose

Logic controlling the accelerator

Major systems:

Timing of RF activation and electron injection

Measurement of the dose produced in each pulse

Logic to determine the remaining number of pulses required

Logic to determine how large the pulses should be

Continual evaluation of key safety signals and interlocks

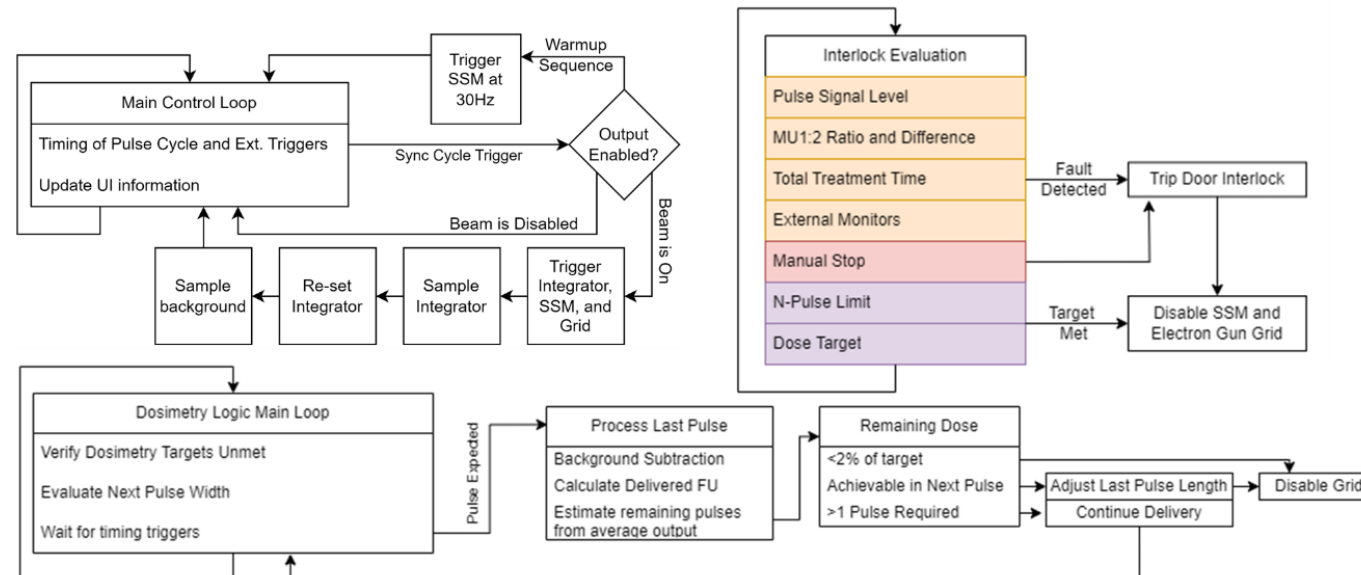

Interfacing with the Mobetron console

The data connections between the FPGA and console must be isolated to protect the equipment.

A custom PCB replaces one control board of the linac and passes signals between the FPGA and Console

This enables direct control over RF system activation timing and pulse duration

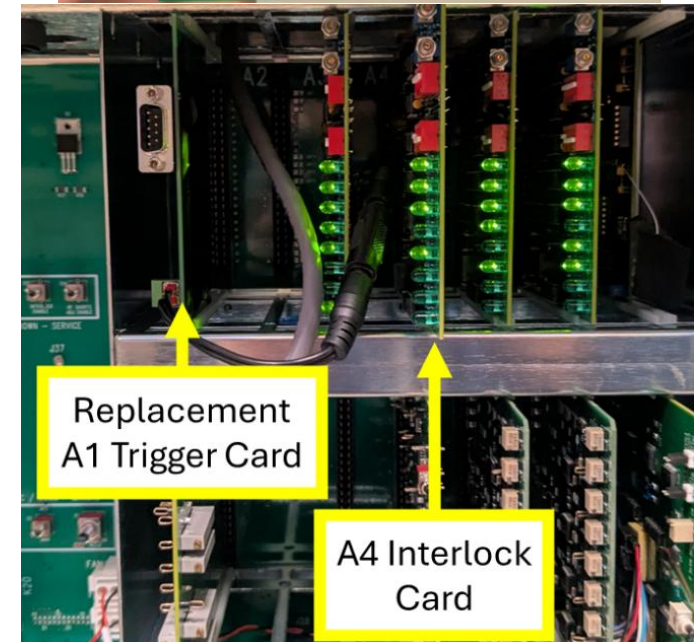
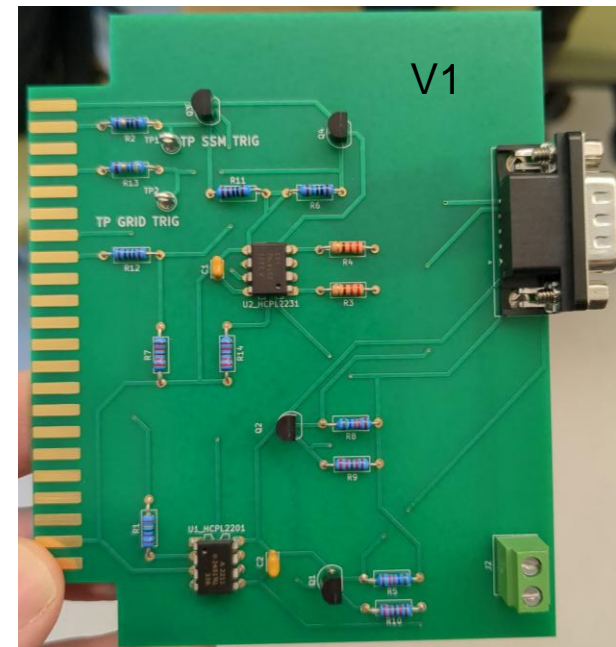

Output-Targeting Performance

Accurate measurement of each pulse across a wide range of PWs

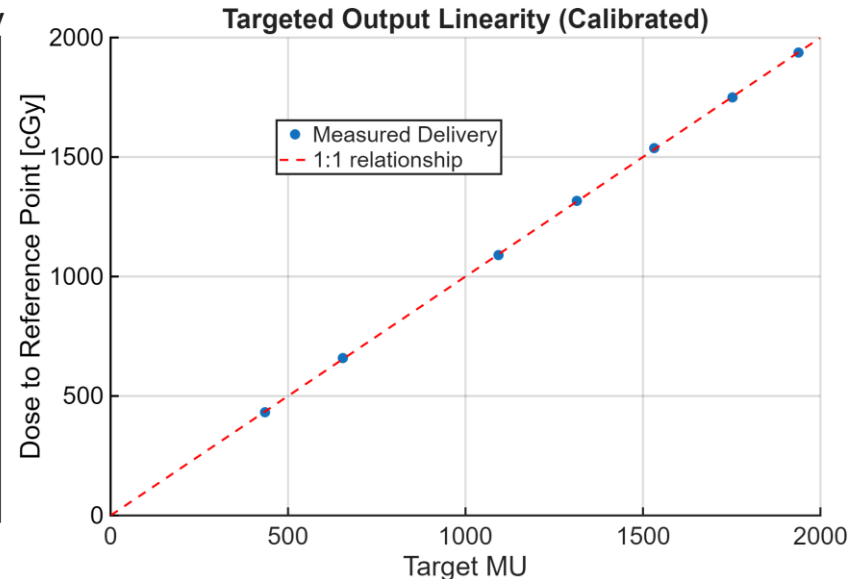
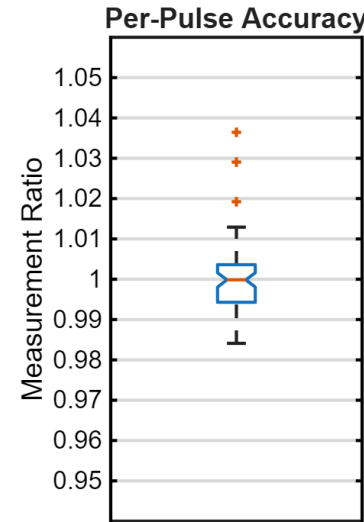

Adjustment of the last pulse achieves <1% accuracy in total output

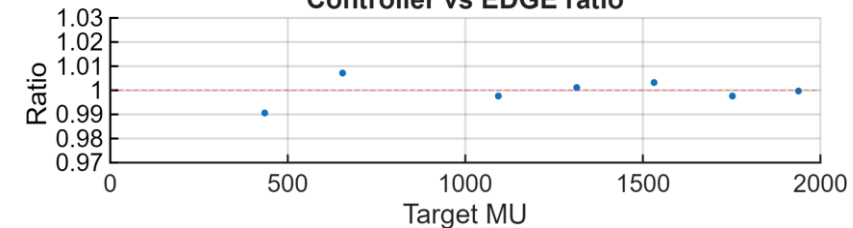

The timing and duration of all pulses is logic-determined

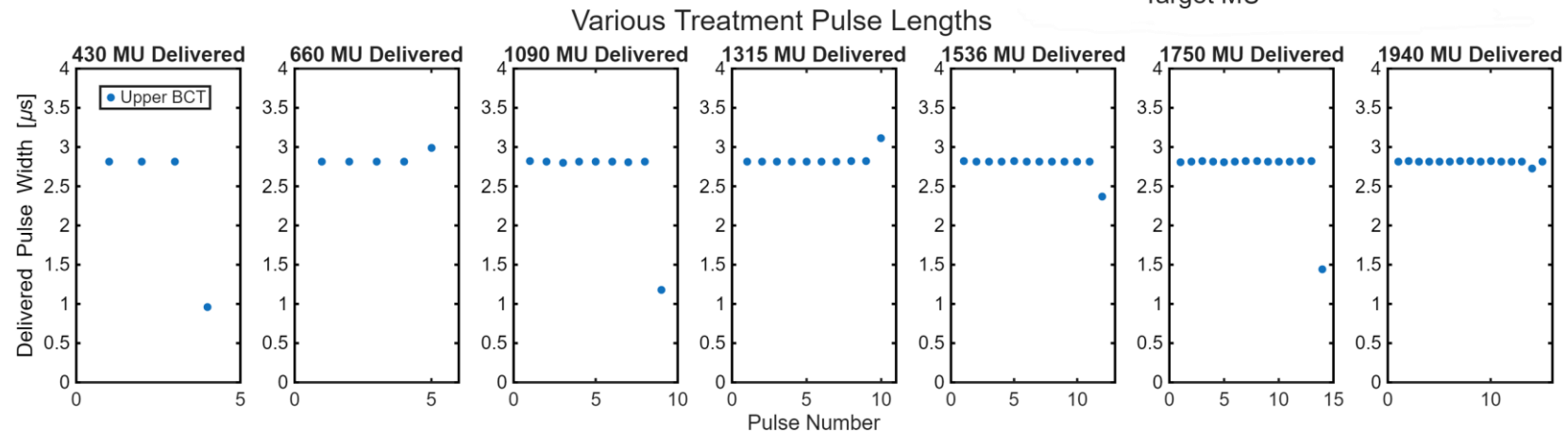

Conclusions

- First demonstration of real-time dosimetry being used as a part of a beam-control system
- First beam-control platform capable of adjusting pulse-to-pulse intensity during a delivery
- This system can increase the reliability of experiment deliveries

Next steps?

- Redundancy
- Simplified electronics
- Hard-mounted installation

Acknowledgements



Questions?