

Intertumoral Oxygen Dynamics Precludes Pre-Irradiation Hyperbaric Oxygen Therapy from Improving Tumor Control in a Murine Glioblastoma Model

Session: Therapy SNAP Oral: Radiation Biology, Modelling and Measurement

Date: July 29th, 2025

David I Hunter, MS¹

Armin Tavakkoli, BA ^{1,2}

Beverly Allen, BS¹

Jay C. Buckey, MD^{1,2}

David J. Gladstone, ScD^{1,2}

P. Jack Hoopes, DVM, PhD^{1,2}

¹Thayer School of Engineering, Dartmouth College, Hanover, New Hampshire

²Geisel School of Medicine, Dartmouth College, Hanover, New Hampshire



Disclosures

- None

Purpose and Background

- Hyperbaric oxygen therapy (**HBOT**) is used to increase plasma pO₂
- Used in: CO poisoning, decompression sickness, chronic wounds, post-irradiation side-effects (Meier et al., Geldof et al., Bennett et al.)
- Oxygen enhances radiation damage; **clinical trials have demonstrated feasibility of neoadjuvant HBOT (Buckey et al.)**

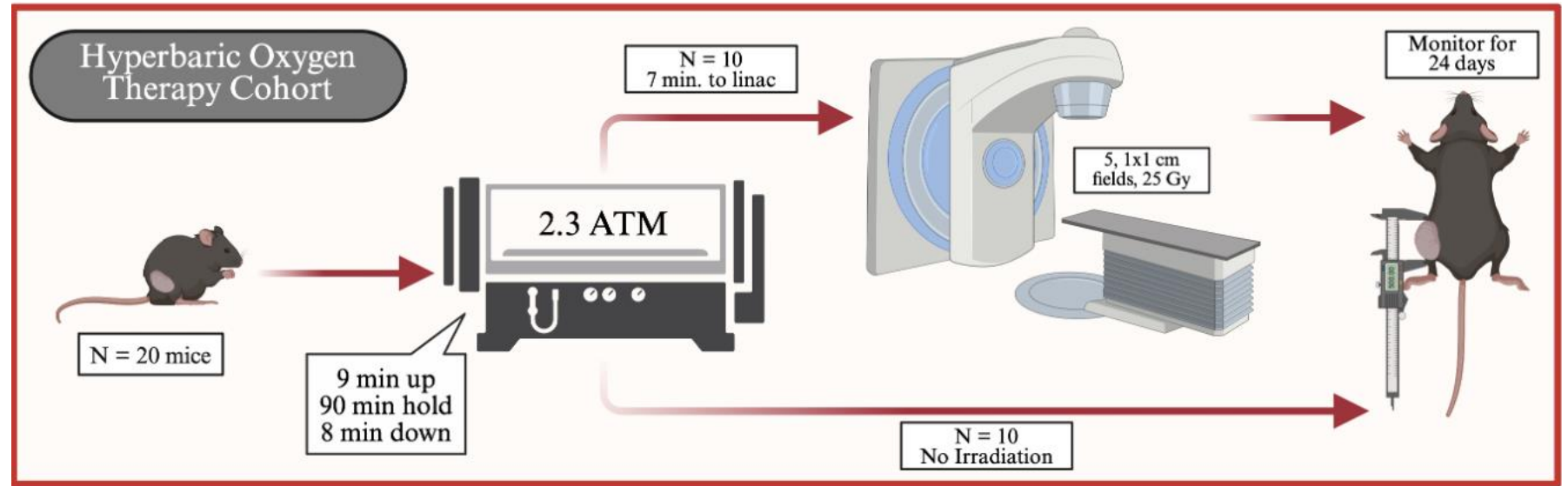
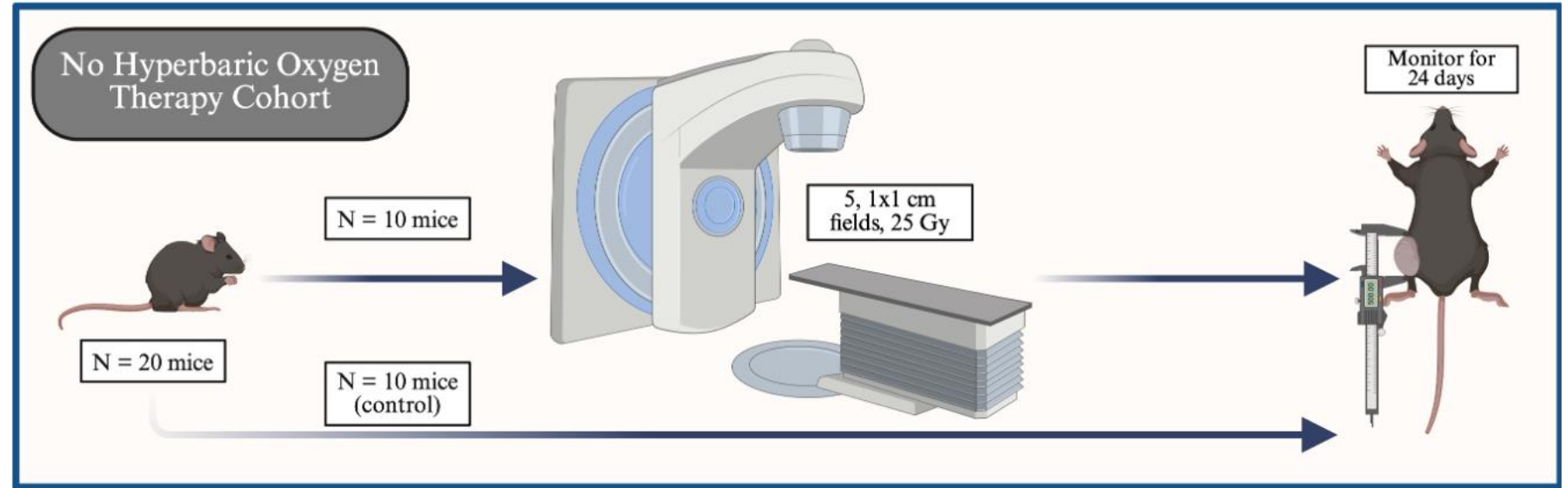
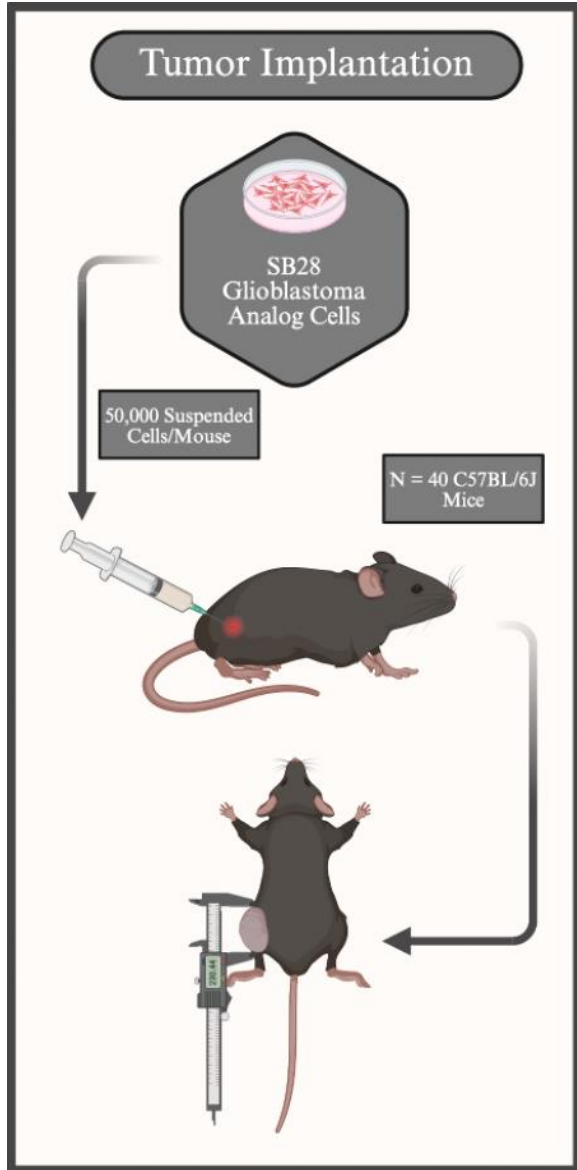

Tumor Response

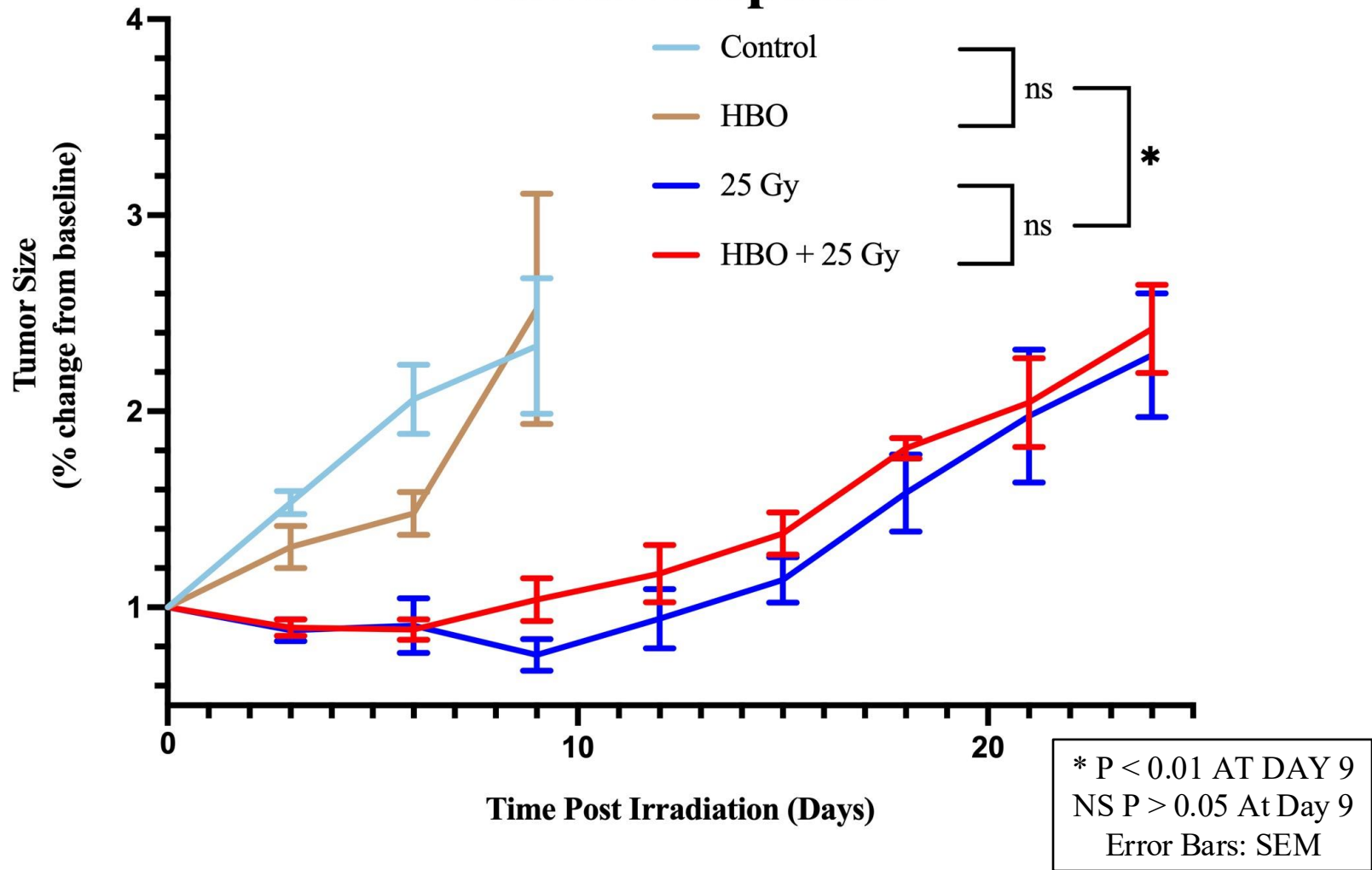



SB28
Glioblastoma
Analog Cells

50,000 suspended cells per-mouse
intra-dermal injection



N = 10 C57BL/6J Mice

Grow tumors to size (100-500mm³)

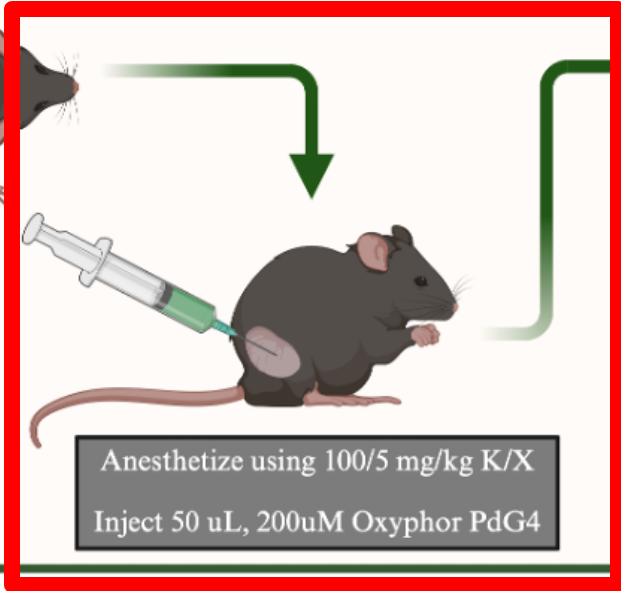
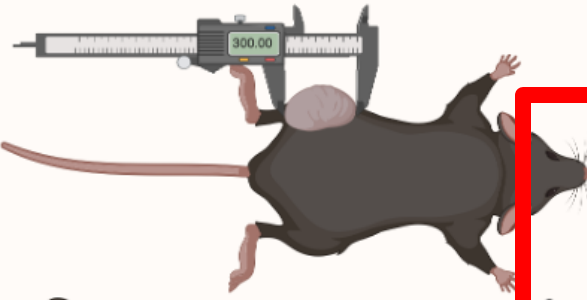

Anesthetize using 100/5 mg/kg K/X
Inject 50 uL, 200uM Oxyphor PdG4

OxyLED used to measure pO₂ during
pressurization, at pressure (2.3 atm), and
depressurization via custom pass-through



Tumor pO₂ Response

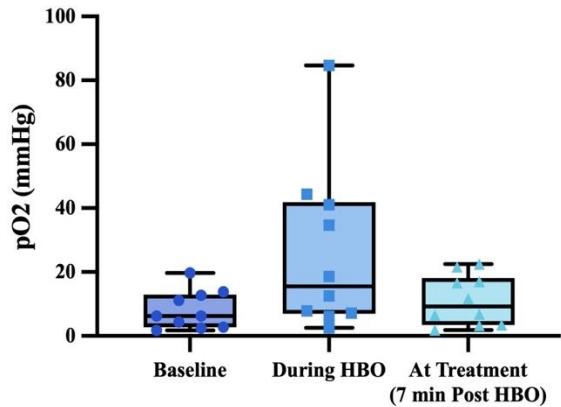

Oxygen Saturation Across Sample Volumes

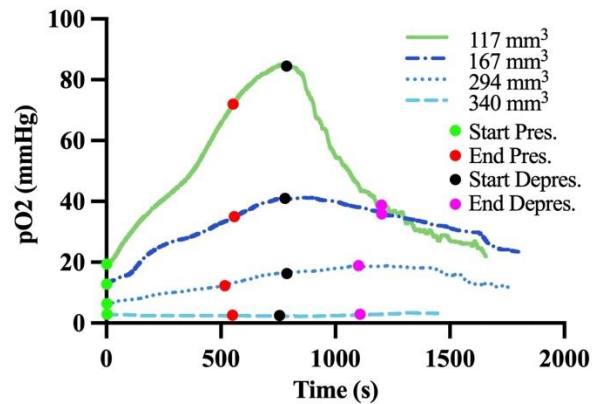

Δ pO₂ (at HBO - Initial) vs. Tumor Volume

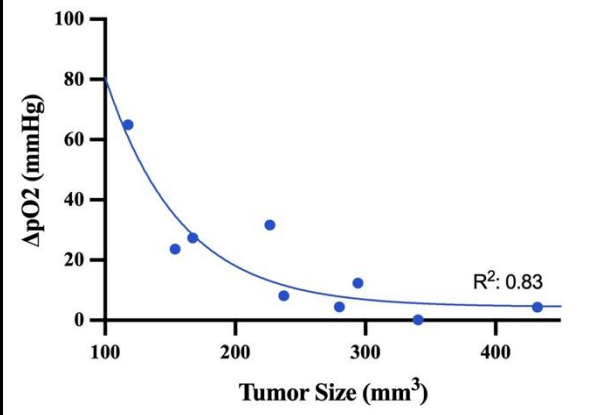

Δ pO₂ (Post - Initial) vs. Tumor Volume

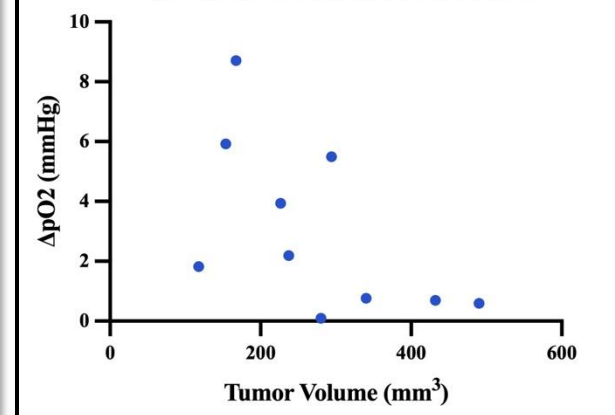

Conclusions

1. Our molecular oxygen reporter has allowed us to gain an insight into the dynamics of oxygenation prior to, during, and post HBOT
2. HBOT may vary pO₂ elevation effect based on solid tumor volume, with larger tumors having lower ΔpO_2 during and after HBOT
3. Mice return to relatively normoxic conditions upon leaving the chamber and being transported to the linear accelerator (**within 7 minutes**)

Acknowledgements and Team



David Hunter, M.S

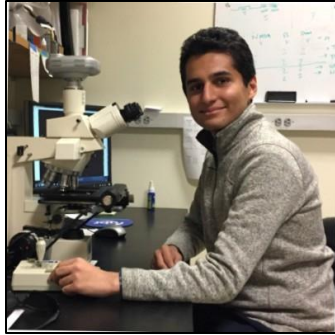

Armin Tavakkoli



Beverly Allen



Jay C. Buckey Jr., MD



David Gladstone, ScD



P. Jack Hoopes,
DVM, PhD



Contact Information (LinkedIn)



This work was supported by a grant from the Dartmouth Cancer Center Prouty Pilot Developmental Fund, as well as the irradiation resources of the Department of Radiation Oncology and Applied Sciences (DROAS).

This work is supported by NIH Grant: P30 CA023108



DARTMOUTH
ENGINEERING
THAYER SCHOOL

engineering.dartmouth.edu



SB28
Glioblastoma
Analog Cells

50,000 suspended cells per-mouse
intra-dermal injection

N = 10 C57BL/6J Mice

Grow tumors to size (100-500mm³)

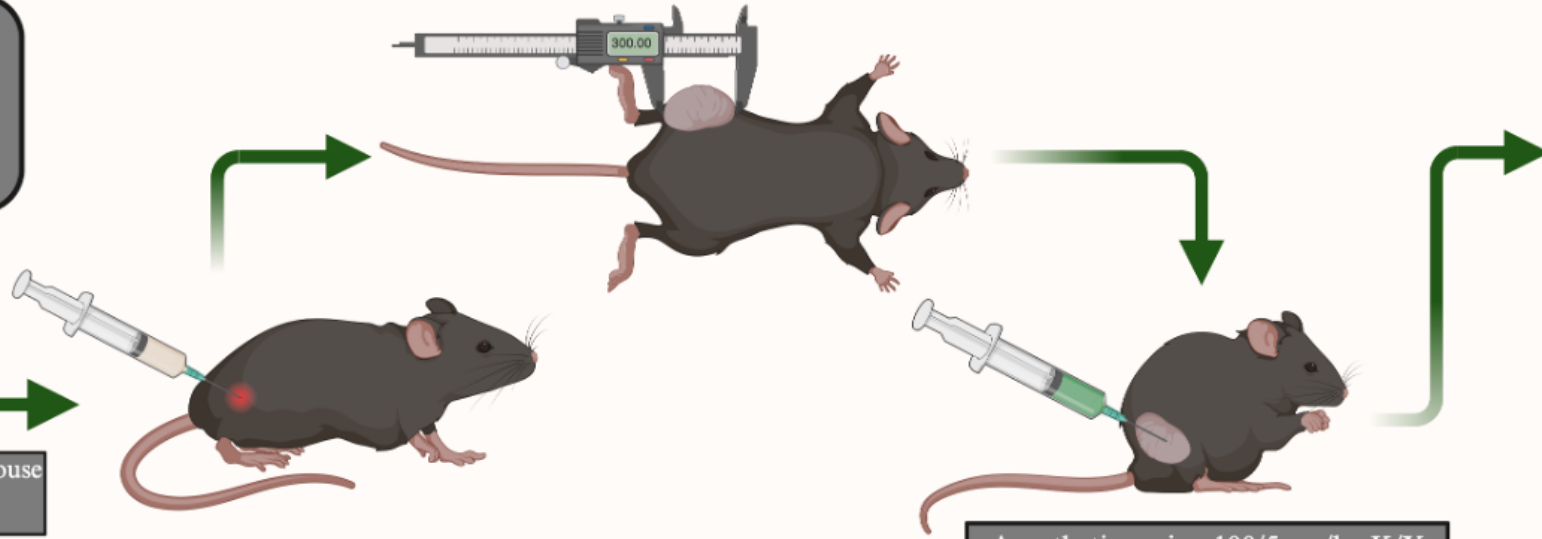

Anesthetize using 100/5 mg/kg K/X
Inject 50 uL, 200uM Oxyphor PdG4

OxyLED used to measure pO₂ during
pressurization, at pressure (2.3 atm), and
depressurization via custom pass-through



Tumor pO₂ Response

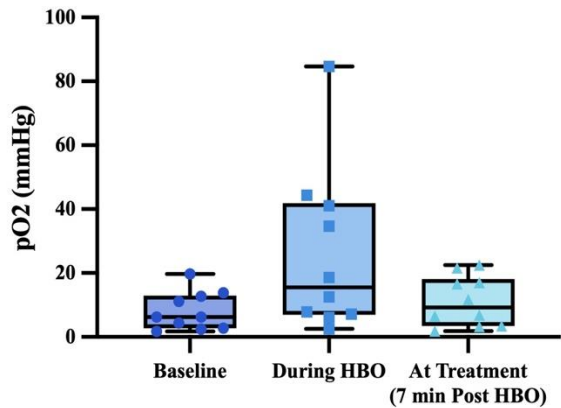

Oxygen Saturation Across Sample Volumes

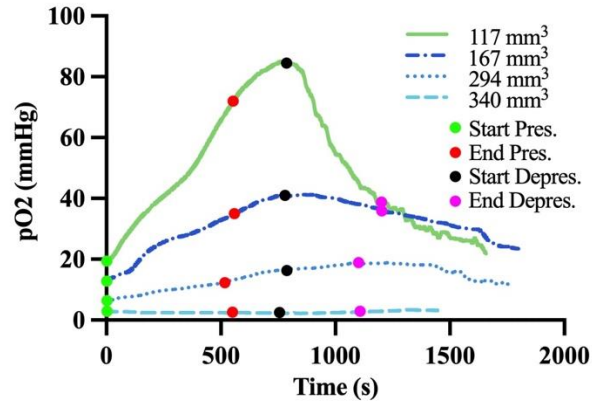

Δ pO₂ (at HBO - Initial) vs. Tumor Volume

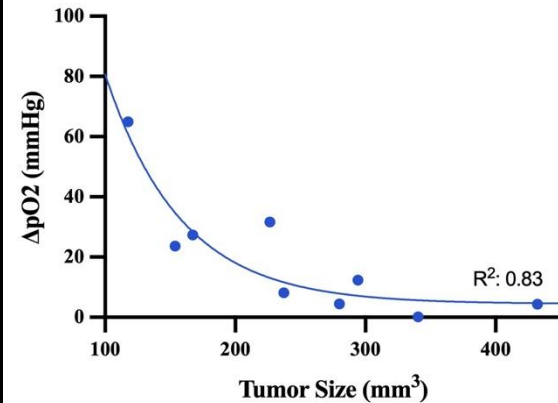

Δ pO₂ (Post - Initial) vs. Tumor Volume

